



TECHNICAL DATA

| | |
|------------------------------------|--|
| Assembly | pole top mounted ø 60 x 80 mm |
| Application | surrounding office buildings, parks, pedestrians, parkings |
| Colour | inox / graphite |
| Ingress protection | IP 66 for the optical part and the driver |
| Optical system | PMMA optics |
| Material | anodised aluminium alloy |
| Unit volume | 0,172 m³ |
| Operating temperature range | from -40°C to +55°C |
| Expected useful lifetime | L90B10 - 100 000 h |
| CRI | >70 |
| Inrush current | 55 A / 200 µs |
| Input voltage frequency | 50/60Hz |
| Power factor | ≥0.95 |
| Number of LED | 16 |
| Control system | Luminaire has the possibility to connect to an external control system via DALI interface (optionally via analog signal 1- 10V). |

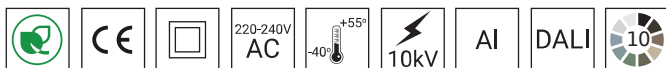

TABLE OF VARIANTS

| Code | Symbol | LED power | Luminaire power consumption | LED forward current | Colour temperature (CCT) | LEDs luminous flux ¹ | Luminaire luminous flux ¹ | Luminous efficacy ¹ | Net weight |
|----------|--------------|-----------|-----------------------------|---------------------|--------------------------|---------------------------------|--------------------------------------|--------------------------------|------------|
| 214432/1 | MIZAR LED 36 | 36 W | 41 W | 750 mA | 2700 K | 5750 lm | 5300 lm | 129 lm/W | 9.6 kg |
| 214432/3 | MIZAR LED 36 | 36 W | 41 W | 750 mA | 3500 K | 6100 lm | 5600 lm | 137 lm/W | 9.6 kg |
| 214432/4 | MIZAR LED 36 | 36 W | 41 W | 750 mA | 4000 K | 6500 lm | 6000 lm | 146 lm/W | 9.6 kg |
| 214432/6 | MIZAR LED 36 | 36 W | 41 W | 750 mA | 5000 K | 6500 lm | 6000 lm | 146 lm/W | 9.6 kg |
| 214433/1 | MIZAR LED 48 | 48 W | 55 W | 1000 mA | 2700 K | 7250 lm | 6700 lm | 122 lm/W | 9.6 kg |
| 214433/3 | MIZAR LED 48 | 48 W | 55 W | 1000 mA | 3500 K | 7700 lm | 7100 lm | 129 lm/W | 9.6 kg |
| 214433/4 | MIZAR LED 48 | 48 W | 55 W | 1000 mA | 4000 K | 8150 lm | 7500 lm | 136 lm/W | 9.6 kg |
| 214433/6 | MIZAR LED 48 | 48 W | 55 W | 1000 mA | 5000 K | 8150 lm | 7500 lm | 136 lm/W | 9.6 kg |

1) tolerance +/- 5% due to LEDs accuracy

DIRECTIVES AND STANDARDS

DIRECTIVES: 2014/35/UE (Official Journal of the UE L 96/357 29.03.2014), 2014/30/UE (Official Journal of the UE L 96/79 29.03.2014), 2011/65/UE RoHS (Official Journal of the UE L 174/88 01.07.2011), 2009/125/EC(Official Journal of the UE L 285/10 31.10.2009)

STANDARDS: PN-EN IEC 60598-1: 2021-7, PN-EN 60598-2-3: 2006, PN-EN 60529: 2003, PN-EN 62262: 2003, PN-EN 62471:2010, PN-EN 55015: 2019, PN-EN 61547: 2009, PN-EN 61000-3-2: 2019 , PN-EN 61000-3-3: 2014

Lighting parameters presented based on laboratory tests according to IESNA LM-79-19

REMOVING ELECTROSTATIC CHARGE FROM LED LUMINAIRE BODY

In order to efficient discharge the electrostatic charge from the housing of LED fitting installed on the pole from dielectric material (non-conductive) one of the following solutions is required:

- functional grounding
- LED luminaire with an additional protection device

TECHNICAL DRAWING

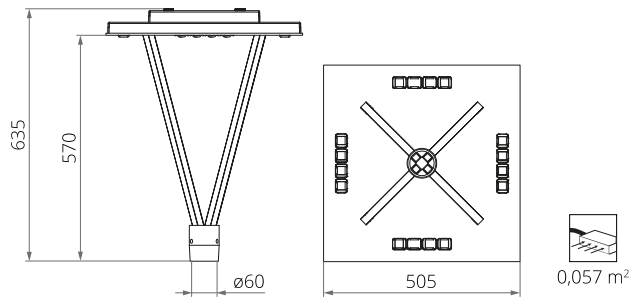

PHOTOMETRIC CURVES

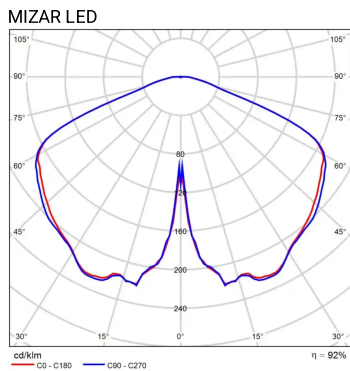

POWER SYSTEM FUNCTIONS

Luminaire in standard has following functions of intelligent power supply:

- Connection to outside control system by DALI interface (operation of analog signal 1-10V as an option),
- Possibility of programming multistage dimming of luminaire, up to 5 intervals in the range of from 10 to 100% of nominal power,
- LED module equipped with thermal protection implemented via an NTC thermistor,
- Regulation of power / luminous flux – the option of setting another value than the catalogue in the range of 30-100% of nominal one,

ACCEPTABLE QUANTITY OF LUMINAIRES ON ONE CIRCUIT

Overcurrent switches MCB type B or C

| Luminaire | Typ | 2A | 4A | 6A | 10A | 16A | 20A | 25A |
|-----------|-----|----|----|----|-----|-----|-----|-----|
| MIZAR LED | B | 1 | 2 | 4 | 6 | 11 | 13 | 17 |
| | C | 1 | 4 | 6 | 11 | 18 | 22 | 28 |

Fuse – type gG and GL

| Luminaire | 2A | 4A | 6A | 10A | 16A | 20A | 25A |
|-----------|----|----|----|-----|-----|-----|-----|
| MIZAR LED | 0 | 4 | 8 | 11 | 21 | 29 | 42 |