



TECHNICAL DATA

Assembly	pole top mounted ø 60 x 80 mm
Application	surrounding office buildings, parks, pedestrians, parkings
Ingress protection	IP 66 for the optical part and the driver
Optical system	PMMA optics, interchangeable LED module
Material	anodised aluminium alloy
Unit volume	-
Operating temperature range	from -40°C to +55°C
Expected useful lifetime	L90B10 - 100 000 h
CRI	>70
Inrush current	43 A / 260 µs
Input voltage frequency	50/60Hz
Power factor	≥0,95
Number of LED	48
Control system	Luminaire has the possibility to connect to an external control system via DALI interface (optionally via analog signal 1- 10V).



TABLE OF VARIANTS

Code	Symbol	LED power	Luminaire power consumption	LED forward current	Colour temperature (CCT)	LEDs luminous flux ¹	Luminaire luminous flux ¹	Luminous efficacy ¹	Net weight
214432/1	MIZAR LED 36	36 W	41 W	280 mA	2700 K	7250 lm	6500 lm	158 lm/W	7,2 kg
214432/3	MIZAR LED 36	36 W	41 W	280 mA	3500 K	7700 lm	6900 lm	168 lm/W	7,2 kg
214432/4	MIZAR LED 36	36 W	41 W	280 mA	4000 K	8150 lm	7300 lm	178 lm/W	7,2 kg
214432/6	MIZAR LED 36	36 W	41 W	280 mA	5000 K	8150 lm	7300 lm	178 lm/W	7,2 kg
214433/1	MIZAR LED 48	48 W	53 W	370 mA	2700 K	9300 lm	8350 lm	157 lm/W	7,2 kg
214433/3	MIZAR LED 48	48 W	53 W	370 mA	3500 K	9900 lm	8900 lm	168 lm/W	7,2 kg
214433/4	MIZAR LED 48	48 W	53 W	370 mA	4000 K	10450 lm	9350 lm	176 lm/W	7,2 kg
214433/6	MIZAR LED 48	48 W	53 W	370 mA	5000 K	10450 lm	9350 lm	176 lm/W	7,2 kg

1) tolerance +/- 5% due to LEDs accuracy

DIRECTIVES AND STANDARDS

DIRECTIVES: 2014/35/UE (Official Journal of the UE L 96/357 29.03.2014), 2014/30/UE (Official Journal of the UE L 96/79 29.03.2014), 2011/65/UE RoHS (Official Journal of the UE L 174/88 01.07.2011), 2009/125/EC(Official Journal of the UE L 285/10 31.10.2009)

STANDARDS: PN-EN IEC 60598-1: 2021-7, PN-EN 60598-2-3: 2006, PN-EN 60529: 2003, PN-EN 62262: 2003, PN-EN 62471:2010, PN-EN 55015: 2019, PN-EN 61547: 2009, PN-EN 61000-3-2: 2019 , PN-EN 61000-3-3: 2014

Lighting parameters presented based on laboratory tests according to IESNA LM-79-19

REMOVING ELECTROSTATIC CHARGE FROM LED LUMINAIRE BODY

In order to efficient discharge the electrostatic charge from the housing of LED fitting installed on the pole from dielectric material (non-conductive) one of the following solutions is required:

- functional grounding
- LED luminaire with an additional protection device

TECHNICAL DRAWING

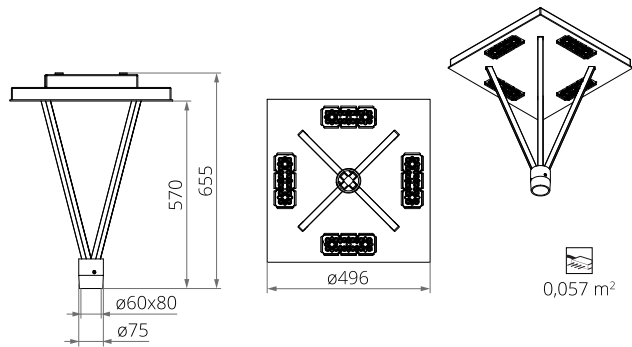

PHOTOMETRIC CURVES

ROSA - Mizar LED 36W 2700K (1x
26_MIZAR_1_36)_Raport.webp

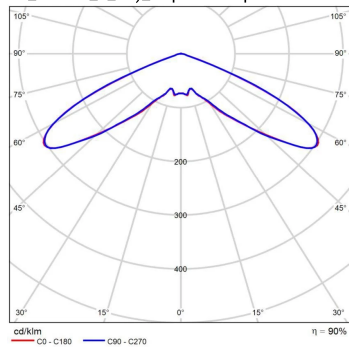

POWER SYSTEM FUNCTIONS

Luminaire in standard has following functions of intelligent power supply:

- Connection to outside control system by DALI interface (operation of analog signal 1-10V as an option),
- Possibility of programming multistage dimming of luminaire, up to 5 intervals in the range of from 10 to 100% of nominal power,
- Regulation of power / luminous flux - the option of setting another value than the catalogue in the range of 30-100% of nominal one,

ACCEPTABLE QUANTITY OF LUMINAIRES ON ONE CIRCUIT

Overcurrent switches MCB type B or C

Luminaire	Typ	2 A	4 A	6 A	10 A	16 A	20 A	25 A
MIZAR LED	B	1	2	4	6	11	13	17
	C	1	4	6	11	18	22	28

Fuse - type gG and GL

Luminaire	2 A	4 A	6 A	10 A	16 A	20 A	25 A
MIZAR LED	0	4	8	11	21	29	42