

Aluminium column SAL-10,3 WZM

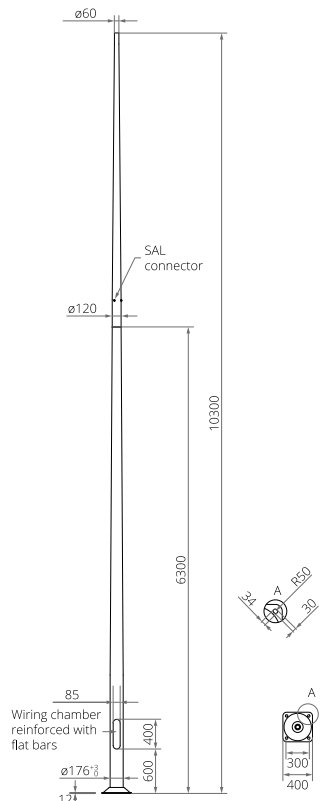

176 mm at the base plate



TECHNICAL DATA

Anodising	10 colours
Luminaire mounting	directly on the column, luminaires with mounting ø60 mm with weight and surface parameters not exceeding the data from the strength table included in the technical data sheet
Extension arm type	according to resistance calculations
Packing	sleeve material
Performance under vehicle impact (passive safety)	Classe 0
Diameter at the base plate	176 mm
Finish	brushed anodised aluminium - anode coating thickness is 20µm as standard (coating thickness of 25µm is also possible), option of elastomer protection up to a height of 350 mm, in a colour similar to the anode colour (other heights or colours of elastomer available according to the RAL palette at the customer's request) - the thickness of the protective coating ranges from 0.8 mm to 1.2 mm
Ingress protection	IP 54 for the wiring chamber without reinforcement
Diameter of the column ending	ø60 mm

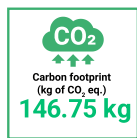

TABLE OF VARIANTS

Code	Symbol	Height of the column [H]	Unit volume	Concrete footing / reinforcement basket type	Concrete footing / reinforcement basket code	Fasteners	Net weight
42478/C...	SAL-10,3 wzm	10.3 m	0.509 m³	B-70 / Z-70	311170 / 311207	4012	56.5 kg

STRENGTH TABLE

SAL-10,3 wzm			Acceptable windage of single luminaire [m²] for Cx=1			
code 42478			Vref. = 22 m/s	Vref. = 24 m/s	Vref. = 26 m/s	Vref. = 28 m/s
code of extension arm	type of extension arm	permissible weight of a single luminaire [kg]	zone I, terrain category II	zone I & III, terrain category II up to 450m a.s.l.	zone II, terrain category II	zone III, terrain category II up to 755m a.s.l.
-	-	30	0,68	0,52	0,41	0,35
472021	WR-2/1/0,95/5	15	0,58	0,44	0,33	0,26
472022	WR-2/2/0,95/5	12	0,27	0,19	0,13	0,10
472023	WR-2/3/0,95/5	10	0,20	0,14	0,10	0,07
472041	WR-4/1/0,6/15	15	0,66	0,51	0,39	0,32
472042	WR-4/2/0,6/15	12	0,31	0,23	0,17	0,14
47204105	WR-4/1/0,5/5	15	0,68	0,53	0,41	0,34
47204205	WR-4/2/0,5/5	12	0,32	0,24	0,18	0,15
47204110	WR-4/1/1,0/5	15	0,61	0,46	0,35	0,28
47204210	WR-4/2/1,0/5	12	0,29	0,21	0,15	0,11
4720419	WR-4/1/0,6/15 ZP	15	0,66	0,51	0,39	0,32
4720429	WR-4/2/0,6/15 ZP	12	0,31	0,23	0,17	0,14
472041059	WR-4/1/0,5/5 ZP	15	0,68	0,53	0,41	0,34
472042059	WR-4/2/0,5/5 ZP	12	0,32	0,24	0,18	0,15
472041109	WR-4/1/1,0/5 ZP	15	0,61	0,46	0,35	0,28
472042109	WR-4/2/1,0/5 ZP	12	0,29	0,21	0,15	0,11
472041159	WR-4/1/1,5/5 ZP	15	0,54	0,40	0,30	0,23
472042159	WR-4/2/1,5/5 ZP	12	0,25	0,17	0,11	0,07
472831	WR-8B/1/0,35/0	15	0,59	0,44	0,34	0,28
472841	WR-8B/1/0,35/5	15	0,59	0,44	0,34	0,28

Aluminium column SAL-10,3 WZM

176 mm at the base plate



SAL-10,3 wzm			Acceptable windage of single luminaire [m²] for Cx=1			
code 42478			Vref. = 22 m/s	Vref. = 24 m/s	Vref. = 26 m/s	Vref. = 28 m/s
code of extension arm	type of extension arm	permissible weight of a single luminaire [kg]	zone I, terrain category II	zone I & III, terrain category II up to 450m a.s.l.	zone II, terrain category II	zone III, terrain category II up to 755m a.s.l.
472851	WR-8B/1/0,35/10	15	0,59	0,44	0,34	0,28
472151	WR-15/1/1,0/5	15	0,55	0,41	0,29	0,22
472152	WR-15/2/1,0/5	12	0,25	0,18	0,11	0,07
472211	WR-21/1/1,5/0	15	0,42	0,30	0,19	0,13
472212	WR-21/2/1,5/0	12	0,19	0,12	0,06	x
472101	WR-T1/1,5/5	15	0,45	0,32	0,22	0,16
472102	WR-T2/1,5/5	12	0,18	0,11	0,05	x
473010	WN-1	15	0,67	0,51	0,40	0,33
473020	WN-2	12	0,32	0,24	0,18	0,15
473030	WN-3	10	0,26	0,19	0,15	0,12
473210	WN-21	12	0,29	0,21	0,15	0,12
473211	WN-21 REG	12	0,25	0,17	0,12	0,09

ANODISING COLOURS

