



TECHNICAL DATA

Assembly	pole top mounted ø 60 x 80 mm
Application	residential roads (internal), surrounding office buildings, parks, pedestrians, bicycle routes
Colour	inox / graphite
Ingress protection	IP 66 for the optical part and the driver
Optical system	PMMA optics, interchangeable LED module
Material	anodised aluminium alloy, diffuser – tempered glass
Unit volume	0,1 m ³
Operating temperature range	from -40°C to +40°C
Expected useful lifetime	L90B10 - 100 000 h
CRI	>70
Inrush current	21 A / 225 µs
Input voltage frequency	50/60Hz
Power factor	≥0.95
Number of LED	16
Control system	Luminaire has the possibility to connect to an external control system via DALI interface (optionally via analog signal 1- 10V).



TABLE OF VARIANTS

Code	Symbol	LED power	Luminaire power consumption	LED forward current	Colour temperature (CCT)	LEDs luminous flux ¹	Luminaire luminous flux ¹	Luminous efficacy ¹	Net weight
214530/1/... ²	MIRA LED 24	24 W	26 W	250 mA	2700 K	4250 lm	3550 lm	137 lm/W	5.4 kg
214530/3/... ²	MIRA LED 24	24 W	26 W	250 mA	3500 K	4450 lm	3700 lm	142 lm/W	5.4 kg
214530/4/... ²	MIRA LED 24	24 W	26 W	250 mA	4000 K	4600 lm	3800 lm	146 lm/W	5.4 kg
214530/6/... ²	MIRA LED 24	24 W	26 W	250 mA	5000 K	4500 lm	3750 lm	144 lm/W	5.4 kg
214532/1/... ²	MIRA LED 36	36 W	39 W	375 mA	2700 K	6200 lm	5150 lm	132 lm/W	5.4 kg
214532/3/... ²	MIRA LED 36	36 W	39 W	375 mA	3500 K	6500 lm	5400 lm	138 lm/W	5.4 kg
214532/4/... ²	MIRA LED 36	36 W	39 W	375 mA	4000 K	6650 lm	5500 lm	141 lm/W	5.4 kg
214532/6/... ²	MIRA LED 36	36 W	39 W	375 mA	5000 K	6550 lm	5450 lm	140 lm/W	5.4 kg

1) tolerance +/- 5% due to LEDs accuracy

DIRECTIVES AND STANDARDS

DIRECTIVES: 2014/35/UE (Official Journal of the UE L 96/357 29.03.2014), 2014/30/UE (Official Journal of the UE L 96/79 29.03.2014), 2011/65/UE RoHS (Official Journal of the UE L 174/88 01.07.2011), 2009/125/EC(Official Journal of the UE L 285/10 31.10.2009)

STANDARDS: PN-EN IEC 60598-1: 2021-7, PN-EN 60598-2-3: 2006, PN-EN 60529: 2003, PN-EN 62262: 2003, PN-EN 62471:2010, PN-EN 55015: 2019, PN-EN 61547: 2009, PN-EN 61000-3-2: 2019 , PN-EN 61000-3-3: 2014

Lighting parameters presented based on laboratory tests according to IESNA LM-79-19

REMOVING ELECTROSTATIC CHARGE FROM LED LUMINAIRE BODY

In order to efficient discharge the electrostatic charge from the housing of LED fitting installed on the pole from dielectric material (non-conductive) one of the following solutions is required:

- functional grounding
- LED luminaire with an additional protection device

TECHNICAL DRAWING

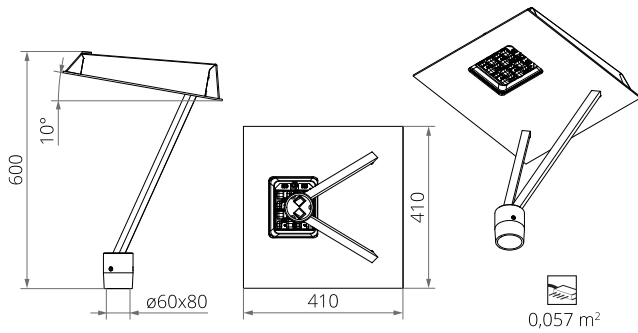

PHOTOMETRIC CURVES

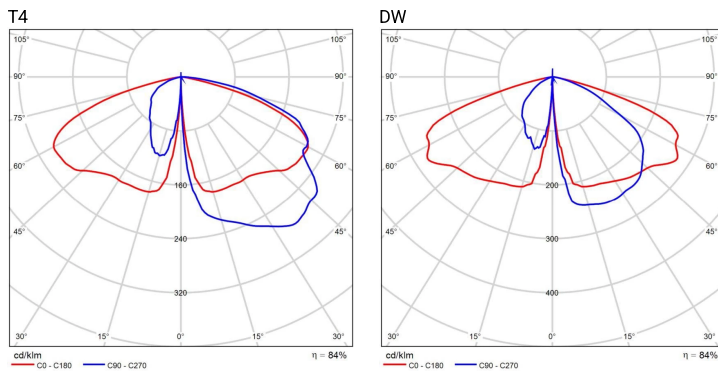

POWER SYSTEM FUNCTIONS

Luminaire in standard has following functions of intelligent power supply:

- Connection to outside control system by DALI interface (operation of analog signal 1-10V as an option),
- Possibility of programming multistage dimming of luminaire, up to 5 intervals in the range of from 10 to 100% of nominal power,
- LED module equipped with thermal protection implemented via an NTC thermistor,
- Regulation of power / luminous flux – the option of setting another value than the catalogue in the range of 30-100% of nominal one,

ACCEPTABLE QUANTITY OF LUMINAIRES ON ONE CIRCUIT

Overcurrent switches MCB type B or C

Luminaire	Type	2A	4A	6A	10A	16A	20A	25A
MIRA LED 24, 36 W	B	4	7	12	18	30	37	46
	C	4	12	18	31	51	62	78

Fuse – type gG and GL

Luminaire	2A	4A	6A	10A	16A	20A	25A
MIRA LED 24, 36 W	1	10	20	26	52	71	101